

Semester 2 (Units 3 and 4) Examination, 2017

Question/Answer Booklet

MATHEMATICS APPLICATIONS

Section Two: Calculator-assumed

Student Name/Number: _____

Teacher Name: _____

Time allowed for this section

Reading time before commencing work: ten minutes

Working time for this section: one hundred minutes

Materials required/recommended for this section

To be provided by the supervisor: This Question/Answer Booklet
Formula Sheet (retained from Section One)

To be provided by the candidate:

Standard items: pens (blue/black preferred), pencils (including coloured), sharpener, correction fluid/tape, eraser, ruler, highlighters

Special items: drawing instruments, templates, notes on 2 unfolded sheets of A4 paper, and up to three calculators approved for use in the WACE examinations

Important note to candidates

No other items may be taken into the examination room. It is **your** responsibility to ensure that you do not have any unauthorised notes or other items of a non-personal nature in the examination room. If you have any unauthorised material with you, hand it to the supervisor **before** reading any further.

Structure of this paper

Section	Number of questions available	Number of questions to be answered	Working time (minutes)	Marks available	Percentage of exam
Section One: Calculator-free	6	6	50	50	35
Section Two: Calculator-assumed	11	11	100	100	65
					100

Instructions to candidates

1. The rules for the conduct of School exams are detailed in the *College assessment policy*. Sitting this examination implies that you agree to abide by these rules.
2. Write your answers in this Question/Answer Booklet.
3. You must be careful to confine your responses to the specific questions asked and to follow any instructions that are specific to a particular question.
4. Spare pages are included at the end of this booklet. They can be used for planning your responses and/or as additional space if required to continue an answer.
 - Planning: If you use the spare pages for planning, indicate this clearly at the top of the page.
 - Continuing an answer: If you need to use the space to continue an answer, indicate in the original answer space where the answer is continued, i.e. give the page number. Fill in the number of the question that you are continuing to answer at the top of the page.
5. **Show all working clearly.** Your working should be in sufficient detail to allow your answers to be checked readily and for marks to be awarded for reasoning. Incorrect answers given without supporting reasoning cannot be allocated any marks. For any question or part question worth more than two marks, valid working or justification is required to receive full marks. If you repeat any question, ensure that you cancel the answer you do not wish to have marked.
6. It is recommended that you **do not use pencil**, except in diagrams.
7. The Formula Sheet is **not** to be handed in with your Question/Answer Booklet.

Section Two: Calculator-assumed

65% (100 Marks)

This section has **11** questions. Answer **all** questions. Write your answers in the spaces provided.

Additional working space pages at the end of this Question/Answer booklet are for planning or continuing an answer. If you use these pages, indicate at the original answer, the page number it is planned/continued on and write the question number being planned/continued on the additional working space page.

Working time: **100 minutes**.

Question 7

(7 marks)

Sales of houses, units and land over the past year for two South-West suburbs are provided. In East Bunbury (EB) 54 houses, 14 units and 8 blocks of land were sold. In West Busselton (WB) 121 houses, 15 units and 43 blocks of land were sold.

- (a) Complete the table showing the numbers sold for each type property. (1 mark)

Suburb	Houses	Units	Blocks
EB	54		
WB			
Totals			

- (b) Complete the percentaged two-way frequency table including the column percentages. (3 marks)

Suburb	Houses	Units	Blocks
EB			
WB			

- (c) Describe the associations between suburb and types of property sold as indicated by the patterns seen in the table in part (b). (3 marks)

Question 8

(10 marks)

Emma has purchased an entertainment system at a cost of \$2400. The “write-off” cost has been estimated as \$500 and the depreciation follows the recursive rule

$$V_{n+1} = 0.96V_n$$

V_n represents the value of the system n months after the system has been purchased.

- (a) Complete the table to show the value of the system at the end of each month.

(2 marks)

n	0	1	2
Value after n months (\$)			

- (b) Determine the rate at which the system is losing value. (1 mark)

- (c) Determine a rule for the n^{th} term. (2 marks)

- (d) Determine the value of the system after one year. (1 mark)

- (e) By what percentage has the system decreased in value after one year? (2 marks)

- (f) If Emma purchased the system at the beginning of July 2017, when will it be “written off”? (2 marks)

Question 9

(7 marks)

The network below shows the maximum number of trains passing along tracks between stations from C to H on each day of the week.

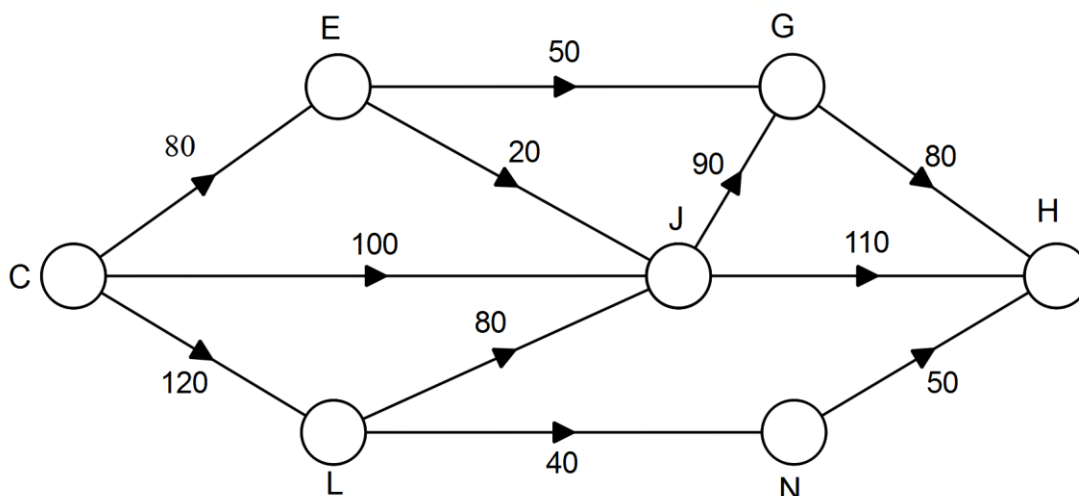

- (a) Determine the maximum number of trains that can travel each day from C to H. (List each path used and the corresponding number of trains). (4 marks)
- (b) What is the maximum number of trains that can pass through Station J? (1 mark)
- (c) Train tracks and timetables can be improved to allow all trains departing each day from Station C to arrive at Station H. For which tracks could capacity be increased? Indicate the smallest increase in the number of trains needed for each track. (2 marks)

Question 10

(11 marks)

The graph below represents the number of cars stolen from Perth airport from Autumn 2011 to Summer 2016. (The data were obtained from the website for WA Police).

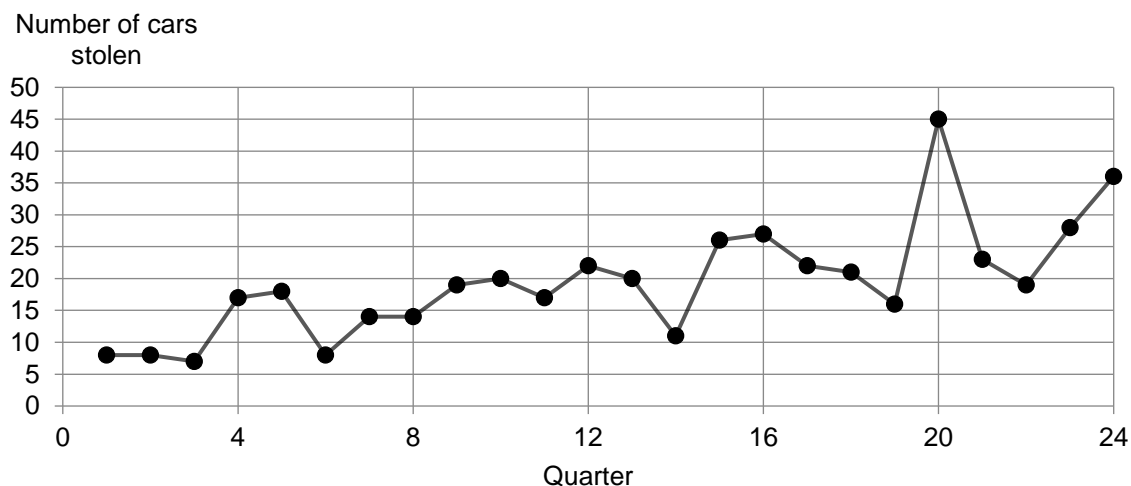

(a) Identify the direction of the trend in the number of car thefts. (1 mark)

(b) Describe the feature of the graph which suggests the data are seasonal. (1 mark)

(c) Circle the data point representing the outlier. (1 mark)

Some of the data collected from the website are summarised on the next page

(d) Calculate the mean for the four seasons in 2015. (1 mark)

(e) The mean for the four seasons in 2011 is 10 thefts per season. Determine the percentage of seasonal mean for Summer 2011 and comment on its significance. (2 marks)

Number of car thefts at Perth airport

Season	Year	Quarter	Number stolen	Percentage of seasonal mean
Autumn	2011	1	8	
Winter		2	8	
Spring		3	7	
Summer		4	17	
Autumn	2012	5	18	133%
Winter		6	8	59%
Spring		7	14	104%
Summer		8	14	104%
Autumn	2013	9	19	97%
Winter		10	20	103%
Spring		11	17	87%
Summer		12	22	113%
Autumn	2014	13	20	95%
Winter		14	11	52%
Spring		15	26	124%
Summer		16	27	129%
Autumn	2015	17	22	85%
Winter		18	21	81%
Spring		19	16	62%
Summer		20	45	173%
Autumn	2016	21	23	87%
Winter		22	19	72%
Spring		23	28	106%
Summer		24	36	136%

- (f) Determine the seasonal index for Winter. (1 mark)
- (g) Determine the deseasonalised number of car thefts for Winter of 2014. (2 marks)
- (h) The graph and table can be used to make several predictions about changes in the number of car thefts. Describe one of these predictions and identify further data that would be needed to test your prediction. (2 marks)

Question 11

(11 marks)

The graph below represents the flight path of a helicopter travelling between towns. The towns are located at the nodes and the edges represent the legs of the flight path.

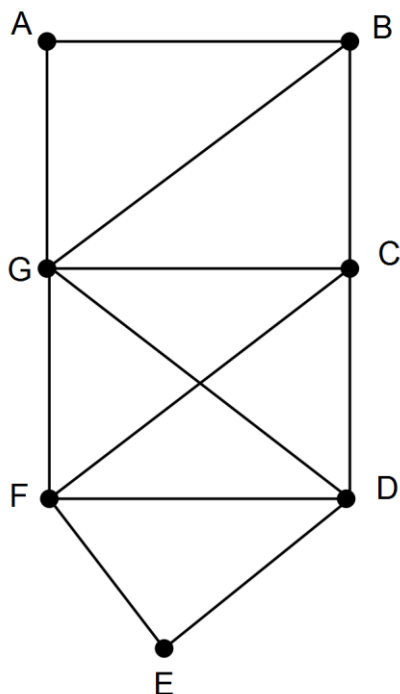

- (a) Redraw the Graph so that it is planar. (1 mark)
- (b) There are two odd vertices in the graph. What are they? (1 mark)
- (c) Starting at one of the odd vertices, determine a flight path that covers all legs once only. (3 marks)
- (d) The graph is semi-Eulerian. Describe two features of the graph which fit this classification. (2 marks)

(e) Without removing any legs of the flight path, change the graph so that it is Eulerian. (1 mark)

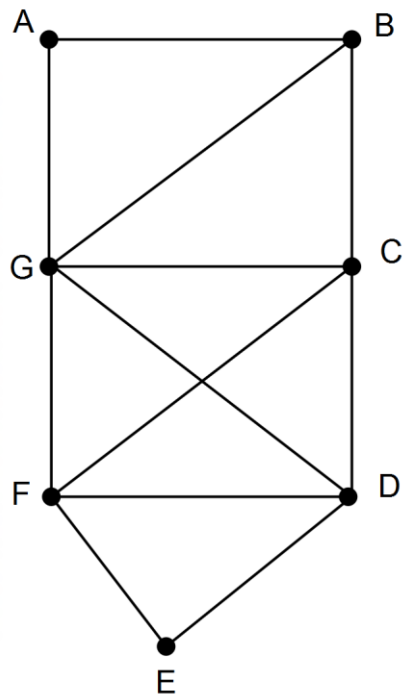

(f) For another flight path there is a total of 11 legs and 6 towns. The graph has two odd vertices. Complete the planar graph to represent the flight path that the helicopter could take. (3 marks)

M
●

N
●

P
●

●
Q

●
R

●
S

Question 12

(14 marks)

Vince receives a gift of \$1000 and he decides to place it into an investment account and save for a holiday. The interest is calculated monthly on the account balance at a rate of 9% per annum. Vince also adds \$200 to the account at the end of each month.

The table below shows the state of the savings for the first three months.

Month	Account balance at the beginning of the month	Interest	Extra savings	Account balance at the end of the month
1	\$1000.00	\$7.50	\$200.00	\$1207.50
2	\$1207.50	\$9.06	\$200.00	\$1416.56
3	\$1416.56	\$10.62	\$200.00	\$1627.18
4				

- (a) Determine the monthly interest rate. (1 mark)
- (b) State the recursive rule to calculate the balance in the account at the end of each month. (2 marks)
- (c) Complete the details for the fourth month. Round all values to the nearest cent. (4 marks)
- (d) Vince intends to travel as soon as his total has reached \$5000. When will this total be reached? (1 mark)

(e) When the total reaches \$5220.28, what component of the total has been earned in interest?
(2 marks)

(f) Which of the following changes to the investment conditions would allow Vince to reach his target more quickly? Tick the correct column in the table to indicate your answers. (4 marks)

Change	Yes – target reached more quickly	No – target not reached more quickly
\$210 is deposited each month.		
Interest rate does not change but it is calculated quarterly instead of monthly.		
Interest rate changes to 0.8% per month.		
\$100 is deposited each fortnight.		

Question 13

(7 marks)

The project network shown below represents the scheduling of 10 activities beginning with Z. The times shown on the edges represent the number of hours for each activity.

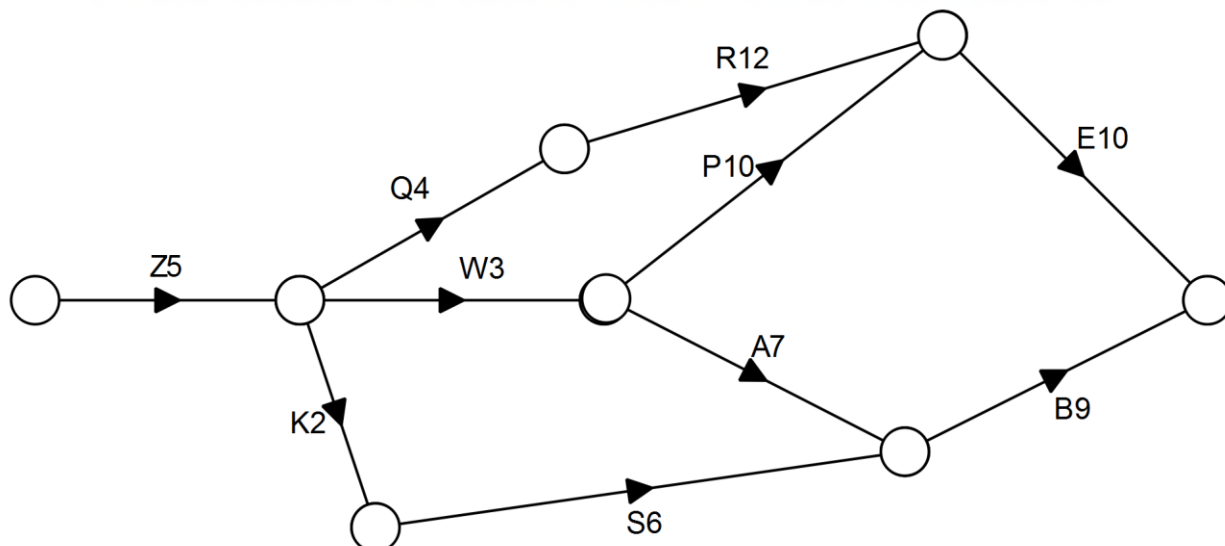

- (a) State the critical path and identify the minimum time to complete all activities. (2 marks)

- (b) What is the earliest time that Activity E can commence? (1 mark)

- (c) What is the latest time that Activity W can commence? (1 mark)

- (d) Determine the float time for Activity S. (1 mark)

- (e) If the time to complete Activity R is increased by 3 hours, what effect does this have on the critical path and the time taken to complete all activities? (2 marks)

Question 14

(8 marks)

Tina has decided to open a term deposit account with \$10 000. Annual interest of 3.05% is compounded monthly and no withdrawals or deposits are allowed.

(a) Determine the amount Tina will have after 3 years.

(1 mark)

(b) Use the formula $i_{\text{effective}} = \left(1 + \frac{i}{n}\right)^n - 1$ to determine the effective annual rate of interest as a percentage correct to 2 decimal places.

(3 marks)

(c) The same bank offers an annual interest rate of 3.10% for interest calculated and paid annually. Is this a better option for Tina? Explain your decision.

(2 marks)

(d) Tina wants to increase the value of her investment after 3 years without changing the amount initially invested. Describe two ways by which the amount can be increased. (2 marks)

Question 15

(9 marks)

Information is received by people through various social media channels.

- (a) One network showing which people receive information and from whom is shown below. The direction of the arrows indicates the direction in which information flows. Between some people, for example, M and A, the flow of information is in both directions.

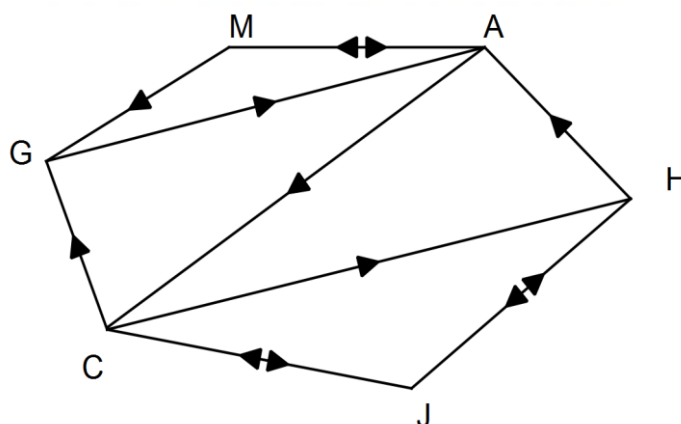

- (a) Complete the adjacency matrix below. The rows represent the source of the information and the columns represent the person receiving the information. (3 marks)

	G	M	A	H	J	C
G	[
M						
A						
H						
J						
C						
]

- (b) Which person has the greatest number of sources of information? Describe how the adjacency matrix can be used to determine this answer? (2 marks)

- (c) For five other people, the adjacency matrix showing the direct flow of information is provided below. Again the columns represent the people receiving the information and the rows represent the source of the information. All communication between people is in two directions.

$$\begin{array}{c}
 J \quad T \quad P \quad H \quad B \\
 \begin{array}{l}
 J \\
 T \\
 P \\
 H \\
 B
 \end{array}
 \begin{bmatrix}
 0 & 1 & 0 & 1 & 0 \\
 1 & 0 & 1 & 0 & 0 \\
 0 & 1 & 0 & 1 & 1 \\
 1 & 0 & 1 & 0 & 1 \\
 0 & 0 & 1 & 1 & 0
 \end{bmatrix}
 \end{array}$$

- (i) Use the matrix to identify an adjacency matrix which represents the number of three-stage communications between these five people. (1 mark)

- (ii) From the adjacency matrix in part (i) determine the number of three-stage communications between persons J and B. List these communications. (3 marks)

Question 16

(9 marks)

Some statistics from an analysis of the average daily electricity consumption are provided below. The period of the study was from June 2011 to April 2015 and data were recorded every two months.

Equation for the least squares line modeling the period from June 2011 to April 2015 is

Deseasonalised data (DADEC) = $-0.142t + 13.4$ where t is the time period

<i>Seasonal indices</i>		<i>t</i>	Date	DADEC
Jun	103%	13	Jun-13	11.6
Aug	89%	14	Aug-13	11.2
Oct	93%	15	Oct-13	10.8
Dec	88%	16	Dec-13	12.5
Feb	112%	17	Feb-14	11.6
Apr	114%	18	Apr-14	11.4
		19	Jun-14	9.7
		20	Aug-14	12.3
		21	Oct-14	10.8
		22	Dec-14	9.1
		23	Feb-15	8.9
		24	Apr-15	9.6

(a) Use the equation to predict the average daily consumption for June 2015. (3 marks)

(b) How reliable is your prediction in part (a)? Justify your decision. (2 marks)

- (c) Determine the equation for the least-squares line that models the change in the deseasonalised average daily consumption (DADEC) from June 2013 to April 2015 using the values of t given in the table. (2 marks)
- (d) What does the difference in the rate of change of the DADEC between the whole four-year period and the last two years indicate about the rate of change during the first two years? Explain your answer. (2 marks)

Question 17**(7 marks)**

Granddad Jim wants advice for his superannuation payout. He has \$450 000 in the account and he has to withdraw 5% in any one year. The investment appears to maintain an 8.5% increase in value from one year to the next but interest is only added at the end of each year.

(a) How much is in Jim's superannuation account at the end of the first year? (2 marks)

(b) Granddad Jim wants to withdraw as much as possible each fortnight without letting the balance go below \$450 000. If interest, deemed to be 8.5% per annum, is added fortnightly and Jim takes out regular fortnightly amounts, how much can he withdraw each fortnight? (2 marks)

(c) Granddad Jim also wants to know how many years he can continue to take an annual sum if the interest rate falls to 6.5% per annum, interest is paid annually at the end of the year and he withdraws his salary at the beginning of each year. There is no requirement that he withdraws 5% but he wants to take an income of \$50 000 for the first five years, \$45 000 for the next five years and then an income of \$40 000 thereafter. (3 marks)

End of Questions

Additional working space

Question number: _____

Acknowledgements

Data for the number of car thefts from Perth Airport was sourced from the website for the W.A. Police. Data for sales of properties in the South-West was obtained from the West Australian newspaper (April, 2017).

© MAWA, 2017

This examination is Copyright but may be freely used within the school that purchases this licence.

- The items that are contained in this examination are to be used solely in the school for which they are purchased.
- They are not to be shared in any manner with a school which has not purchased their own licence.
- The items and the solutions/markings keys are to be kept confidentially and not copied or made available to anyone who is not a teacher at the school. Teachers may give feedback to students in the form of showing them how the work is marked but students are not to retain a copy of the paper or marking guide until the agreed release date stipulated in the purchasing agreement/licence.

*Published by The Mathematical Association of WA
12 Cobbler Place, MIRRABOOKA 6...*